



# A comparative study of LPWAN technologies for large-scale IoT deployment

Kais Mekki<sup>a,\*</sup>, Eddy Bajic<sup>a</sup>, Frederic Chaxel<sup>a</sup>, Fernand Meyer<sup>b</sup>

<sup>a</sup> *Research Centre for Automatic Control of Nancy, Campus Sciences, BP 70239, Vandoeuvre, 54506, France*

<sup>b</sup> *OKKO SAS, 34 Rue Nationale, Puttelange-aux-Lacs, 57510, France*

Received 21 September 2017; accepted 20 December 2017

Available online 4 January 2018

## Abstract

By 2020, more than 50 billion devices will be connected through radio communications. In conjunction with the rapid growth of the Internet of Things (IoT) market, low power wide area networks (LPWAN) have become a popular low-rate long-range radio communication technology. Sigfox, LoRa, and NB-IoT are the three leading LPWAN technologies that compete for large-scale IoT deployment. This paper provides a comprehensive and comparative study of these technologies, which serve as efficient solutions to connect smart, autonomous, and heterogeneous devices. We show that Sigfox and LoRa are advantageous in terms of battery lifetime, capacity, and cost. Meanwhile, NB-IoT offers benefits in terms of latency and quality of service. In addition, we analyze the IoT success factors of these LPWAN technologies, and we consider application scenarios and explain which technology is the best fit for each of these scenarios.

© 2018 The Korean Institute of Communications and Information Sciences (KICS). Publishing Services by Elsevier B.V. This is an open access article under the CC BY-NC-ND license (<http://creativecommons.org/licenses/by-nc-nd/4.0/>).

*Keywords:* Internet of Things; LPWAN; LoRa; Sigfox; NB-IoT

## 1. Introduction

The Internet of Things (IoT) refers to the inter connection and exchange of data among devices/sensors. Currently, with the explosive growth of the IoT technologies, an increasing number of practical applications can be found in many fields including security, asset tracking, agriculture, smart metering, smart cities, and smart homes [1]. IoT applications have specific requirements such as long range, low data rate, low energy consumption, and cost effectiveness. The widely used short-range radio technologies (e.g., ZigBee, Bluetooth) are not adapted for scenarios that require long range transmission. Solutions based on cellular communications (e.g., 2G, 3G, and 4G) can provide larger coverage, but they consume excessive device energy. Therefore, IoT applications' requirements have driven the emergence of a new wireless communication technology: low power wide area network (LPWAN).

LPWAN is increasingly gaining popularity in industrial and research communities because of its low power, long range, and low-cost communication characteristics. It provides long-range communication up to 10–40 km in rural zones and 1–5 km in urban zones [2]. In addition, it is highly energy efficient (i.e. 10+ years of battery lifetime [3]) and inexpensive, with the cost of a radio chipset being less than 2€ and an operating cost of 1€ per device per year [4]. These promising aspects of LPWAN have prompted recent experimental studies on the performance of LPWAN in outdoor and indoor environments [5–7]. In summary, LPWAN is highly suitable for IoT applications that only need to transmit tiny amounts of data in long range, as shown in Fig. 1. As recently as early 2013, the term “LPWAN” did not even exist [8]. Many LPWAN technologies have arisen in the licensed as well as unlicensed frequency bandwidth. Among them, Sigfox, LoRa, and NB-IoT are today's leading emergent technologies that involve many technical differences.

The Sigfox technology was developed in 2010 by the start-up Sigfox (in Toulouse, France), which is both a company

\* Corresponding author.

E-mail address: [kais.mekki@univ-lorraine.fr](mailto:kais.mekki@univ-lorraine.fr) (K. Mekki).

Peer review under responsibility of The Korean Institute of Communications and Information Sciences (KICS).

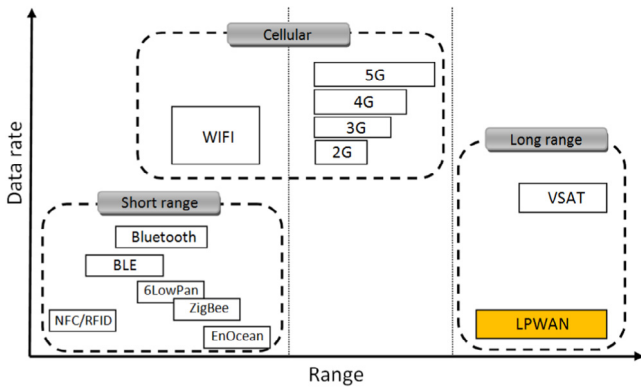

**Fig. 1.** Required data rate vs. range capacity of radio communication technologies: LPWAN positioning.

and an LPWAN network operator. Sigfox operates and commercializes its own IoT solution in 31 countries and is still under rollout worldwide owing to the partnership with various network operators [9]. LoRa was first developed by the start-up Cycleo in 2009 (in Grenoble, France) and was purchased three years later by Semtech (USA). In 2015, LoRa was standardized by LoRa-Alliance and is deployed in 42 countries and is still under rollout in other countries owing to the investment of various mobile operators (e.g., Bouygues and Orange in France, KPN in Netherlands, and Fastnet in South Africa) [10].

NB-IoT is an LPWAN technology based on narrow band radio technology and is standardized by the 3rd generation partnership project (3GPP). Its specifications were published in Release 13 of the 3GPP on June 2016. The NB-IoT is still under test in Europe. In December 2016, Vodafone and Huawei integrated NB-IoT into the Spanish Vodafone network and sent the first message conforming to the NB-IoT standard to a device installed in a water meter. Currently, Huawei is multiplying partnerships to deploy this technology worldwide (it was announced to be deployed in many countries in 2018). In May 2017, the Ministry of Industry and Information Technology in China announced its decision to accelerate the commercial use of NB-IoT for utilities and smart city applications.

In this paper, the technical differences of Sigfox, LoRa, and NB-IoT are presented and compared in terms of physical/communication features. In addition, these technologies are compared in terms of IoT success factors such as quality of service (QoS), coverage, range, latency, battery life, scalability, payload length, deployment, and cost. Further, we consider application scenarios and explain which technology fits best.

The remainder of this paper is organized as follows: Section 2 describes the technical features of Sigfox, LoRa, and NB-IoT. Section 3 compares them in terms of IoT factors. Section 4 explains which technology fits best for different application scenarios. Finally, Section 5 discusses and concludes the paper.

## 2. Technical differences: SIGFOX, LORA, and NB-IOT

In this section, we highlight the emerging proprietary technologies and the technical aspects of Sigfox, LoRa, and NB-IoT as summarized in Table 1.

### 2.1. Sigfox

Sigfox is an LPWAN network operator that offers an end-to-end IoT connectivity solution based on its patented technologies. Sigfox deploys its proprietary base stations equipped with cognitive software-defined radios and connect them to the back end servers using an IP-based network. The end devices connected to these base stations using binary phase-shift keying (BPSK) modulation in an ultra-narrow band (100 Hz) sub-GHZ ISM band carrier. Sigfox uses unlicensed ISM bands, for example, 868 MHz in Europe, 915 MHz in North America, and 433 MHz in Asia. By employing the ultra-narrow band, Sigfox uses the frequency bandwidth efficiently and experiences very low noise levels, leading to very low power consumption, high receiver sensitivity, and low-cost antenna design at the expense of maximum throughput of only 100 bps. Sigfox initially supported only uplink communication, but later evolved to bidirectional technology with a significant link asymmetry. The downlink communication, i.e., data from the base stations to the end devices can only occur following an uplink communication. The number of messages over the uplink is limited to 140 messages per day. The maximum payload length for each uplink message is 12 bytes. However, the number of messages over the downlink is limited to four messages per day, which means that the acknowledgment of every uplink message is not supported. The maximum payload length for each downlink message is eight bytes. Without the adequate support of acknowledgments, the uplink communication reliability is ensured using time and frequency diversity as well as transmission duplication. Each end-device message is transmitted multiple times (three by default) over different frequency channels. For this purpose, in Europe for example, the band between 868.180 MHz and 868.220 MHz is divided into 400 orthogonal 100 Hz channels (among them 40 channels are reserved and not used) [4]. As the base stations can receive messages simultaneously over all channels, the end device can randomly choose a frequency channel to transmit their messages. This simplifies the end-device design and reduces its cost.

### 2.2. LoRa

LoRa is a physical layer technology that modulates the signals in sub-GHZ ISM band using a proprietary spread spectrum technique [11]. Like Sigfox, LoRa uses unlicensed ISM bands, i.e., 868 MHz in Europe, 915 MHz in North America, and 433 MHz in Asia. The bidirectional communication is provided by the chirp spread spectrum (CSS) modulation that spreads a narrow-band signal over a wider channel bandwidth. The resulting signal has low noise levels, enabling high interference resilience, and is difficult to detect or jam [12].

LoRa uses six spreading factors (SF7 to SF12) to adapt the data rate and range tradeoff. Higher spreading factor allows longer range at the expense of lower data rate, and vice versa. The LoRa data rate is between 300 bps and 50 kbps depending on spreading factor and channel bandwidth. Further, messages transmitted using different spreading factors can be received simultaneously by LoRa base stations [13]. The maximum

**Table 1**

Overview of LPWAN technologies: Sigfox, LoRa, and NB-IoT.

	Sigfox	LoRaWAN	NB-IoT
Modulation	BPSK	CSS	QPSK
Frequency	Unlicensed ISM bands (868 MHz in Europe, 915 MHz in North America, and 433 MHz in Asia)	Unlicensed ISM bands (868 MHz in Europe, 915 MHz in North America, and 433 MHz in Asia)	Licensed LTE frequency bands
Bandwidth	100 Hz	250 kHz and 125 kHz	200 kHz
Maximum data rate	100 bps	50 kbps	200 kbps
Bidirectional	Limited / Half-duplex	Yes / Half-duplex	Yes / Half-duplex
Maximum messages/day	140 (UL), 4 (DL)	Unlimited	Unlimited
Maximum payload length	12 bytes (UL), 8 bytes (DL)	243 bytes	1600 bytes
Range	10 km (urban), 40 km (rural)	5 km (urban), 20 km (rural)	1 km (urban), 10 km (rural)
Interference immunity	Very high	Very high	Low
Authentication & encryption	Not supported	Yes (AES 128b)	Yes (LTE encryption)
Adaptive data rate	No	Yes	No
Handover	End-devices do not join a single base station	End-devices do not join a single base station	End-devices join a single base station
Localization	Yes (RSSI)	Yes (TDOA)	No (under specification)
Allow private network	No	Yes	No
Standardization	Sigfox company is collaborating with ETSI on the standardization of Sigfox-based network	LoRa-Alliance	3GPP

**Fig. 2.** Bidirectional communication between end-device and base station for LoRaWAN class A.

payload length for each message is 243 bytes. A LoRa-based communication protocol called LoRaWAN was standardized by LoRa-Alliance (first version in 2015). Using LoRaWAN, each message transmitted by an end device is received by all the base stations in the range. By exploiting this redundant reception, LoRaWAN improves the successfully received messages ratio. However, achieving this feature requires multiple base stations in the neighborhood, which may increase the network deployment cost. The resulting duplicate receptions are filtered in the backend system (network server) that also has the required intelligence for checking security, sending acknowledgments to the end device, and sending the message to the corresponding application server. Further, multiple receptions of the same message by different base stations are exploited by LoRaWAN for localizing end devices. For this purpose, the time difference of arrival (TDOA)-based localization technique supported by very accurate time synchronization between multiple base stations is used. Moreover, multiple receptions of the same message at different base stations avoid the handover in LoRaWAN network (i.e., if a node is mobile or moving, handover is not needed between the base stations).

In addition, LoRaWAN provides various classes of end devices to address the different requirements of a wide range of IoT applications, e.g., latency requirements.

- *Bidirectional end devices (class A)*: class-A end devices allow bidirectional communications where by each end-device's uplink transmission is followed by two short downlink receive windows as shown in Fig. 2. The transmissions lot scheduled by the end device is based

on its own communication needs with a small variation based on a random time basis. This class-A operation is the lowest power end-device system for applications that only require short downlink communication after the end device has sent an uplink message. Downlink communications at any other time will have to wait until the next uplink message of the end device.

- *Bidirectional end devices with scheduled receives lots (class B)*: in addition to the random receive windows of class A, class B devices open extra receive windows at scheduled times. To open receive windows at the scheduled time, end devices receive a time-synchronized beacon from the base station. This allows the network server to know when the end device is listening.
- *Bidirectional end devices with maximal receive slots (class C)*: class C end devices have almost continuously open receive windows, and only close when transmitting at the expense of excessive energy consumption.

The specifications of the next version of LoRaWAN are still being developed by LoRa-Alliance [10]. The new features expected are roaming, class-B clarification, and the temporary switching between class A and class C.

### 2.3. NB-IoT

NB-IoT is a Narrow Band IoT technology specified in Release 13 of the 3GPP in June 2016. NB-IoT can coexist with GSM (global system for mobile communications) and LTE (long-term evolution) under licensed frequency bands (e.g., 700

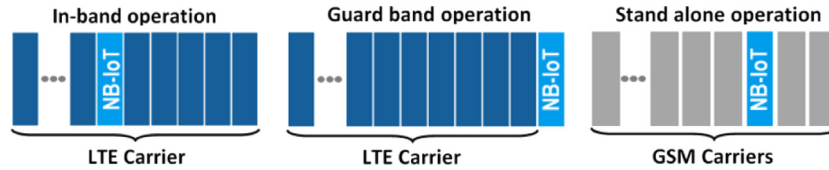

Fig. 3. Operation modes for NB-IoT.

MHz, 800 MHz, and 900 MHz). NB-IoT occupies a frequency band width of 200 KHz, which corresponds to one resource block in GSM and LTE transmission [14]. With this frequency band selection, the following operation modes are possible, as shown in Fig. 3:

- *Stand-alone operation*: a possible scenario is the utilization of GSM frequencies bands currently used.
- *Guard-band operation*: utilizing the unused resource blocks within an LTE carrier’s guard band.
- *In-band operation*: utilizing resource blocks within an LTE carrier.

For the stand-alone operation, the GSM carriers in the right part of Fig. 3 are shown as an example to indicate that the operation is possible in NB-IoT deployment. In fact, the 3GPP recommends the integration of NB-IoT in conjunction with the LTE cellular networks. NB-IoT can be supported with only a software upgrade in addition to the existing LTE infrastructure.

The NB-IoT communication protocol is based on the LTE protocol. In fact, NB-IoT reduces LTE protocol functionalities to the minimum and enhances them as required for IoT applications. For example, the LTE backend system is used to broadcast information that is valid for all end devices within a cell. As the broadcasting back end system obtains resources and consumes battery power from each end device, it is kept to a minimum, in size as well as in its occurrence. It was optimized to small and infrequent data messages and avoids the features not required for the IoT purpose, e.g., measurements to monitor the channel quality, carrier aggregation, and dual connectivity. Therefore, the end devices require only a small amount of battery, thus making it cost-efficient.

Consequently, NB-IoT technology can be regarded as a new air interface from the protocol stack point of view, while being built on the well-established LTE infrastructure. NB-IoT allows connectivity of up to 100 K end devices per cell with the potential for scaling up the capacity by adding more NB-IoT carriers. NB-IoT uses the single-carrier frequency division multiple access (FDMA) in the uplink and orthogonal FDMA (OFDMA) in the downlink, and employs the quadrature phase-shift keying modulation (QPSK) [14]. The data rate is limited to 200 kbps for the downlink and to 20 kbps for the uplink. The maximum payload size for each message is 1600 bytes. As discussed in [15], NB-IoT technology can achieve 10 years of battery lifetime when transmitting 200 bytes per day on average.

The improvement of NB-IoT continues with Release 15 of the 3GPP. According to the 3GPP’s current plan, the NB-IoT will be extended to include localization methods, multi-cast services (e.g., end-devices software update and messages

concerning a whole group of end devices), mobility, as well as further technical details to enhance the applications of the NB-IoT technology.

### 3. Comparison in terms of IoT factors

Many factors should be considered when choosing the appropriate LPWAN technology for an IoT application including quality of service, battery life, latency, scalability, payload length, coverage, range, deployment, and cost. In the following, Sigfox, LoRa and NB-IoT are compared in terms of these factors and their technical differences.

#### 3.1. Quality of service

Sigfox and LoRa employ unlicensed spectra and asynchronous communication protocols. They can bounce interference, multipath, and fading. However, they cannot offer the same QoS provided by NB-IoT. NB-IoT employs a licensed spectrum and an LTE-based synchronous protocol, which are optimal for QoS at the expense of cost, i.e., licensed LTE spectrum auctions are over 500 million euro per MHz [8]. Owing to QoS and cost tradeoff, NB-IoT is preferred for applications that require guaranteed quality of service, whereas applications that do not have this constraint should choose LoRa or Sigfox.

#### 3.2. Battery life & Latency

In Sigfox, LoRa, and NB-IoT, end devices are in sleep mode most of the time outside operation, which reduce the amount of consumed energy, i.e., long end-devices lifetime. However, the NB-IoT end device consumes additional energy because of synchronous communication and QoS handling, and its OFDM/FDMA access modes require more peak current [16]. This additional energy consumption reduces the NB-IoT end-device lifetime as compared to Sigfox and LoRa.

However, NB-IoT offers the advantage of low latency. Unlike Sigfox, LoRa provides class C to also handle low-bidirectional latency at the expense of increased energy consumption. Therefore, for applications that are insensitive to the latency and do not have large amount of data to send, Sigfox and class-A LoRa are the best options. For applications that require low latency, NB-IoT and class-C LoRa are the better choices.

#### 3.3. Scalability & Payload length

The support of the massive number of devices is one of the key features of Sigfox, LoRa, and NB-IoT. These technologies

**Table 2**  
Different costs of Sigfox, LoRa, and NB-IoT.

	Spectrum cost	Deployment cost	End-device cost
Sigfox	Free	>4000€/base station	<2€
LoRa	Free	>100€/gateway >1000€/base station	3–5€
NB-IoT	>500 M€ /MHz	>15 000€/base station	>20€

work well with the increasing number and density of connected devices. Several techniques are considered to cope with this scalability feature such as the efficient exploitation of diversity in a channel, as well as in time and space. However, NB-IoT offers the advantage of very high scalability than Sigfox and LoRa. NB-IoT allows connectivity of up to 100 K end devices per cell compared to 50 K per cell for Sigfox and LoRa [13].

Nevertheless, NB-IoT also offers the advantage of maximum payload length. As presented in Table 1, NB-IoT allows the transmission of data of up to 1600 bytes. LoRa allows a maximum of 243 bytes of data to be sent. In contrary, Sigfox proposes the lowest payload length of 12 bytes, which limits its utilization on various IoT applications that need to send large data sizes.

### 3.4. Network coverage & Range

The major utilization advantage of Sigfox is that an entire city can be covered by one single base station (i.e., range >40 km). In Belgium, a country with a total surface area of approximately 30 500 km<sup>2</sup>, the Sigfox network deployment covers the entire country with only seven base stations [8].

By contrast, LoRa has a lower range (i.e., range <20 km) that requires only three base stations to cover an entire city such as Barcelona. NB-IoT has the lowest range and coverage capabilities (i.e., range <10 km). It focuses primarily on the class of devices that are installed at places far from the typical reach of cellular networks (e.g., indoors, deep indoors). In addition, the deployment of NB-IoT is limited to LTE base stations. Thus, it is not suitable for rural or suburban regions that do not benefit from LTE coverage.

### 3.5. Deployment model

The NB-IoT specifications were released in June 2016; thus, additional time will be needed before its network is established. However, the Sigfox and LoRa ecosystems are mature and are now under commercialization in various countries and cities. LoRa has the advantage that allows it to be currently deployed in 42 countries versus 31 countries for Sigfox [9,10]. Nevertheless, the world wide deployments of LoRa and Sigfox are still under rollout.

In addition, one significant advantage of LoRa ecosystem is its flexibility. Unlike Sigfox and NB-IoT, LoRa offers local network deployment, i.e., LAN using LoRa gateway as well as public network operation via base stations. In the industrial field, a hybrid operating model could be used to deploy a local LoRa network in factory areas and uses the public LoRa network to cover the outside areas.

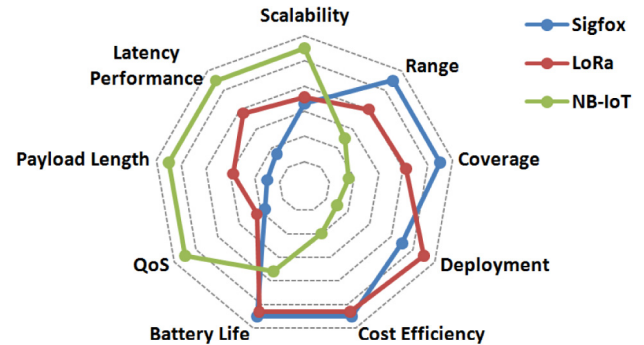

**Fig. 4.** Respective advantages of Sigfox, LoRa, and NB-IoT in terms of IoT factors.

### 3.6. Cost

Various cost aspects need to be considered such as spectrum cost (license), network/deployment cost, and device cost. Table 2 shows the cost of Sigfox, LoRa, and NB-IoT. It is apparent that Sigfox and LoRa are more cost-effective compared to NB-IoT.

In summary, Sigfox, LoRa, and NB-IoT each has their respective advantages in terms of different IoT factors as shown in Fig. 4.

## 4. Application examples: which technology fits best?

The IoT factors and technical differences of Sigfox, LoRa, and NB-IoT will determine their feasibility for specific applications. As discussed in this paper, one technology cannot equally serve all IoT applications. In this section, various application use cases are discussed with a summary of the best-fitting technology.

### 4.1. Electric metering

In the electric metering market, companies typically require frequent communication, low latency, and high data rate. Typically, they require neither low energy consumption nor long battery life time as electric meters have continuous power source. Moreover, companies need real-time grid monitoring to make immediate decisions, e.g., load, outages, and interruptions. Thus, Sigfox is inappropriate for this application as it does not handle low latency. On the contrary, electric meters can be setup using class-C LoRa to ensure very low latency. However, NB-IoT is a better fit for this application because of the required high data rate and frequent communication. Moreover, electric meters are typically found in stationary locations in densely populated areas. Therefore, it is easy to ensure NB-IoT coverage by cellular operators (LTE).

#### 4.2. Smart farming

In agriculture, the long battery lifetime of sensor devices are required. Temperature, humidity, and alkalinity sensors could significantly reduce water consumption and improve yield. The devices update sensed data a few times per hour as the environment conditions have not radically changed. Thus, Sigfox and LoRa are ideal for this application. Moreover, many farms today do not have LTE cellular coverage; thus, NB-IoT is not the solution for agriculture in the near future.

#### 4.3. Manufacturing automation

Real-time machinery monitoring prevents industrial production line down and allows remote control to improve efficiency. In factory automation, various types of sensors and communication requirements exist. Some applications require frequent communication and high-quality service, thus NB-IoT is a better solution than Sigfox and LoRa. Other applications require low-cost sensors and long battery lifetime for asset tracking and status monitoring; in this case, Sigfox and LoRa are a better solution. Because of the various requirements, hybrid solutions could also be used.

#### 4.4. Smart building

Temperature, humidity, security, water flow, and electric plugs sensors alert property managers to prevent damages and instantly respond to requests without having a manual building monitor. The buildings' cleaning and usage could also be carried out more efficiently. These sensors require low cost and long battery lifetime. They do not require quality of service or frequent communication, therefore Sigfox and LoRa are a better fit for this class of applications.

#### 4.5. Retail point of sale terminals

Sale-point systems require guaranteed quality of service as they handle frequent communications. These systems have continuous electrical power source, thus there is no constraint on battery lifetime. There is also a strong requirement of low latency, i.e., long latency times limit the number of transactions that a store can make. Thus, NB-IoT is a better fit for this application.

#### 4.6. Pallet tracking for logistics

Currently, pallets tracking to determine the goods' location and condition are highly desirable in logistics. In this application, the most sought-after requirements are device cost and battery lifetime. Pallet tracking is a good example of a hybrid-deployment solution. Logistics companies can have their own network to ensure guaranteed coverage in their facilities. Low-cost IoT devices could be easily deployed on vehicles. Sigfox or LoRa public base stations can then be used when vehicles are outside the facilities or when goods arrive at customer locations. However, LoRa allows more reliable communications than

Sigfox when moving at high speeds [3]. For NB-IoT, the LTE network might not be available in all logistic locations, typically in rural areas. Owing to the low cost, long battery lifetime, and reliable mobile communications, LoRa is a better fit for this application.

### 5. Conclusion

This paper has summarized the technical differences of Sigfox, LoRa, and NB-IoT, and discussed their advantages in terms of IoT factors and major issues. Each technology will have its place in the IoT market. Sigfox and LoRa will serve as the lower-cost device, with very long range (high coverage), infrequent communication rate, and very long battery lifetime. Unlike Sigfox, LoRa will also serve the local network deployment and the reliable communication when devices move at high speeds. By contrast, NB-IoT will serve the higher-value IoT markets that are willing to pay for very low latency and high quality of service.

Despite the cellular companies' tests, the lack of NB-IoT commercial deployments currently leaves open questions on the actual battery lifetime and the performance attainable by this technology in real-world conditions. Finally, it is expected that 5th generation (5G) wireless mobile communication will provide the means to allow an all-connected world of humans and devices by the year 2020, which would lead to a global LPWAN solution for IoT applications.

### Conflict of interest

All the authors declare that there is no conflict of interest regarding the publication of this paper.

### References

- [1] R. Ratasuk, N. Mangalvedhe, A. Ghosh, Overview of LTE enhancements for cellular IoT, in: Proc. of PIMRC, Hong Kong, China, 2015, pp. 2293–2297.
- [2] M. Centenaro, L. Vangelista, A. Zanella, M. Zorzi, Long-range communications in unlicensed bands: The rising stars in the IoT and smart city scenarios, *IEEE J. Wirel. Comm.* 23 (5) (2016) 60–67.
- [3] D. Patel, M. Won, Experimental study on low power wide area networks for mobile internet of things, in: Proc. of VTC, Sydney, Australia, 2017, pp. 1–5.
- [4] U. Raza, P. Kulkarni, M. Sooriyabandara, Low power wide area networks: An overview, *IEEE J. Commun. Surv. Tuto.* 19 (2) (2017) 855–873.
- [5] A.M. Baharudin, W. Yan, Long-range wireless sensor networks for geo-location tracking: Design and evaluation, in: Proc. of IES, Denpasar, Indonesia, 2016, pp. 76–80.
- [6] W. Guibene, J. Nowack, N. Chalikias, M. Kelly, Evaluation of LPWAN technologies for smart cities: River monitoring use-case, in: Proc. of WCNCW, San Francisco, CA, USA, 2017, pp. 17–22.
- [7] O. Vondrous, Z. Kocur, T. Hegr, O. Slavicek, Performance evaluation of IoT mesh networking technology in ISM frequency band, in: Proc. of ME, Prague, Czech Republic, 2016, pp. 1–8.
- [8] R. Sinha, Y. Wei, S. Hwang, A survey on LPWA technology: LoRa and NB-IoT, *J. ICT Expr.* 3 (2017) 14–21.
- [9] Sigfox world coverage available in: [www.sigfox.com/en/coverage/](http://www.sigfox.com/en/coverage/).
- [10] LoRa world coverage available in: [www.lora-alliance.org/](http://www.lora-alliance.org/).
- [11] F. Sforza, Communications system, 26 March 2013, US Patent US8406275 B2.

- [12] B. Reynders, W. Meert, S. Pollin, Range and coexistence analysis of long range unlicensed communication, in: Proc. of ICT, Thessaloniki, Greece, 2016, pp. 51–56.
- [13] K. Mikhaylov, T. Haenninen, Analysis of capacity and scalability of the LoRa low power wide area network technology, in: Proc. of EWC, Oulu, Finland, 2016, pp. 119–124.
- [14] [Y.E. Wang, X. Lin, A. Grovlen, Y. Sui, J. Bergman, A primer on 3GPP narrowband internet of things, IEEE Commun. Mag. 55 \(3\) \(2016\) 117–123.](#)
- [15] A. Adhikary, X. Lin, Y.-P.E. Wang, Performance evaluation of NB-IoT coverage, in: Proc. of VTC-Fall, Montreal, QC, Canada, 2016, pp. 65–69.
- [16] [S.-M. Oh, J. Shin, An efficient small data transmission scheme in the 3GPP NB-IoT system, IEEE Commun. Lett. 21 \(3\) \(2017\) 660–663.](#)